

# A Lesson on Digital Clocks, One Shots and Counters



© J. Chris Perez 2001

## Topics

- Clocks & Oscillators
  - LM 555 Timer IC
  - Crystal Oscillators
  - Selection of Variable Resistors
  - Schmitt Gates
  - Power-On Reset Circuits
  - One Shots
- Counters
  - Binary Counters
  - Mod-n Counters
  - Frequency Division Using Counters

© J. Chris Perez 2001

## Two Types of Digital Circuits

- Combinational: outputs at any instant of time are entirely dependent on the inputs present at that time
- Sequential: external outputs are a function of external inputs but also the present state

© J. Chris Perez 2001

## Sequential Circuits

- Synchronous: system whose behavior is defined by its signals and states at discrete instances of time
- Asynchronous: system whose behavior depends upon the order in which its input signals change and can be affected at any instance of time

© J. Chris Perez 2001

## What is a clock?

A clock is a device with no inputs and one output, defined by:

- Frequency
- Duty Cycle
- Magnitude

$$f = 1/T$$

$$DC = +pw/T * 100$$

where: +pw is positive pulse width and T is period

© J. Chris Perez 2001

## LM555 Timer IC

The 555 is a multi-function device. Function depends on external configuration and components.

Clock (Astable)

One-Shot (Monostable)

Pulse-Width Modulator

And others...

© J. Chris Perez 2001

## LM555 Clock

$$f = 1.44 / [ C1 * (Ra + 2Rb) ]$$

range:  $\approx 0.01$  Hz to 1.00 MHz

$$dc = 100 * \{ 1 - [Rb / (Ra + 2Rb) ] \}$$

range: 50 to 100 %

Magnitude = 0 V to +V  
range: 4.5 to 16V

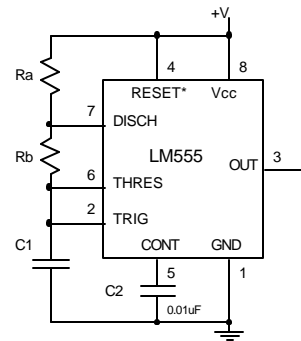

© J. Chris Perez 2001

## LM555 Clock Example

Design a clock circuit using a 555 timer IC to produce a TTL clock with the given specs:

$$f = 9600 \text{ Hz} \quad dc = 66.7 \%$$

Step 1: Select C1. Let C1 = 0.01  $\mu$ F

Step 2: Solve Ra vs. Rb ratio.

$$66.7 = 100 * \{ 1 - [Rb / (Ra + 2Rb)] \}$$

$$1.0 Rb = Ra$$

Step 3: Solve for Exact Values

$$9600 \text{ Hz} = 1.44 / [0.01 \mu\text{F} * (Ra + 2Rb)]$$

$$9600 \text{ Hz} / 1.44 = 1 / [0.01 \mu\text{F} * (3.0 * Rb)]$$

$$Rb = 5000 \Omega \quad \therefore Ra = Rb = 5000 \Omega$$

© J. Chris Perez 2001

## Crystal Oscillators

Crystals: A crystal is made from a thinly cut piece of quartz sandwiched between two metal leads.

Quartz crystals force oscillation at their natural (mechanical) frequency (or harmonics).

The natural frequency is primarily a function of quartz thickness.

Crystals stabilize the frequency of an oscillating circuit. They provide extremely good frequency stability (0.001 %).

© J. Chris Perez 2001

## Crystal Oscillator Circuits

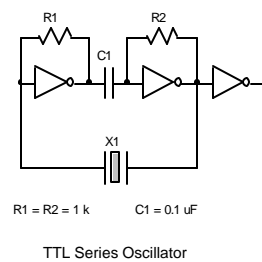
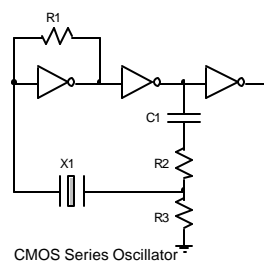

Equations for CMOS Series Oscillator:

$$R1 = 5\text{ M}\Omega * e^{-(10 * 10^{-6}f)}$$

$$R2 = 0.12 * R1$$

$$R3 = R2 / (0.3 V_{cc} - 0.5)$$

Use the TTL circuit for  
Lab 3

© J. Chris Perez 2001

## Selection Of Variable Resistors

Variable resistors or potentiometers (pots) are used to provide variable:

- frequencies
- duty cycles
- pulse widths

They are also used to fine tune circuits to exact values. Fixed resistors do not come in every value. Pots can be used to get any value. However pots should be used with a series resistor.

© J. Chris Perez 2001

Example: Design a clock that can produce a variable frequency output in the range 1200 to 9600 Hz.

Step 1. Keeping C, and Ra the same, compute Rb for both frequencies.

Assume	1200 Hz	9600 Hz
Rb =	7.0K Ohms	2.7K Ohms

Step 2. Use a combination of a fixed resistor in series with a pot for Rb such that:

$$R_{\text{fixed}} < 2.7\text{K Ohms}$$

$$R_{\text{fixed}} + R_{\text{pot}} > 7.0\text{K Ohms}$$

Solution:

$$R_{\text{fixed}} = 2.2\text{K}, \quad R_{\text{pot}} = 5\text{K}$$

$$2.2\text{K} < R_b < 7.2\text{K}$$

Keep the resistance of the pot large to have maximum variability. A small turn of the pot results in big change in frequency.

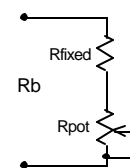

© J. Chris Perez 2001

Example: A clock of frequency 9600 Hz  $\pm$  0.1% is needed.

$R_b = 5000$  Ohms

- tolerance of resistors 20, 10, 5, 1%

- tolerance of capacitors +80% to -20%

Solution: Large fixed resistor in series with a small pot.

$R_{\text{fixed}} = 4700$  Ohms,  $R_{\text{pot}} = 1\text{K}$  Ohms

$4700$  Ohms  $< R_b < 5700$  Ohms

Keep the fixed resistor value large compared to the pot to get best accuracy or maximum precision.

CAUTION: Use pots sparingly:

- cost:  $\$_{\text{spots}} > \$_{\text{fixed}}$

$\$$  to adjust

- mechanical: noisy, unreliable

© J. Chris Perez 2001

## Schmitt Gates

### Schmitt Gate Characteristics

- Schmitt gates are essentially TTL inverters that treat inputs slightly different from normal CMOS or TTL.
- The input logic level is always defined.
- Schmitt-trigger inputs have different input threshold levels depending on the direction of the input signal. (Hysteresis)
  - Inputs going from a low to a high voltage affect the output at  $V_{t+}$  (positive threshold).
  - Inputs going from a high to a low voltage affect the output at  $V_{t-}$  (negative threshold).

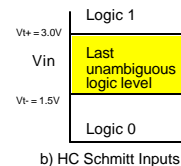
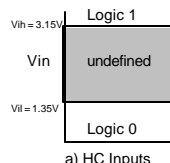
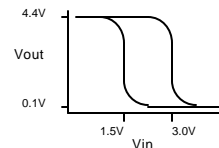
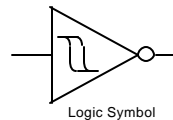

© J. Chris Perez 2001

# Schmitt Gates

## Schmitt Gate Applications

- Signal Conditioning: cleaning up noisy, or distorted digital signals
- Line Drivers & Receivers
- Clocks & Delay Circuits

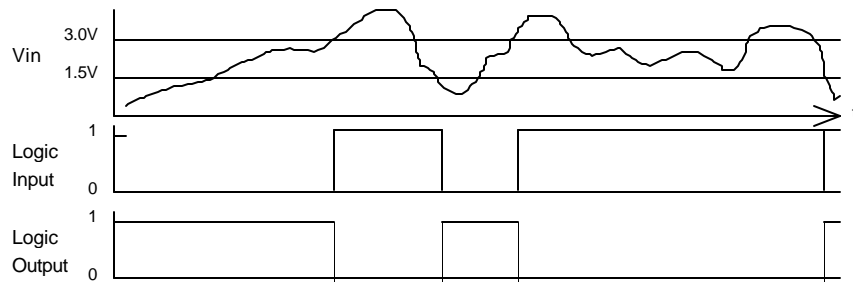

© J. Chris Perez 2001

# Schmitt Inverter Clock

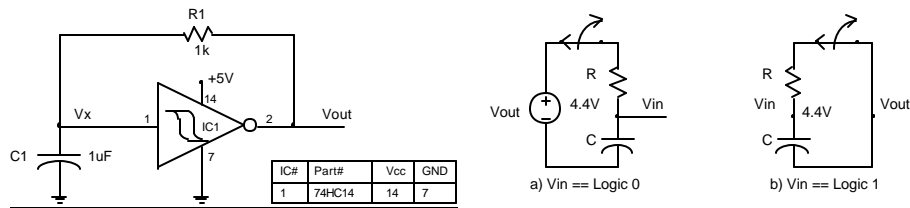

Assume C1 discharged before power is applied. Then  $V_x = 0.0V$ . Since  $V_x = V_{in} = \text{logic } 0$ , when power is applied  $V_{out}$  goes high (logic 1).

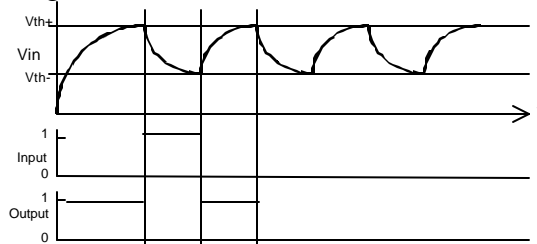

$$f \approx \frac{1}{RC \ln 2.26}$$

© J. Chris Perez 2001



**One Shot -- Monostable Multi-vibrators**

A one-shot is a circuit that produces a stable output (logic 1 or 0) until a trigger (+ or - edge) occurs. The trigger will cause the one-shot to produce a quasi-stable output for a time period determined by the circuit configuration. After the specified period of time, the output returns to the stable state.

The pulse width of the quasi-stable state is independent of external stimulus. Usually, the pulse width is a function of a RC time constant.

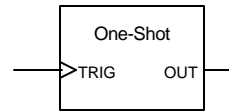

$$T_w = f(R,C) = 0.7RC \text{ (for a 74LS221)}$$

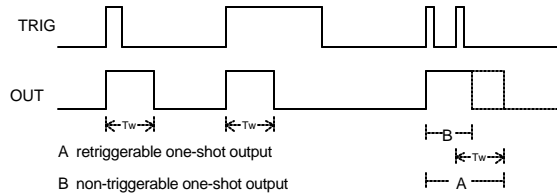

© J. Chris Perez 2001

# 74LS221 Dual One-Shot

The 74LS221 is a dual version of the 74LS121 TTL one-shot. The '221 has either a positive or negative edge trigger, and an active-high, or active-low output.

$$T_w = \ln 2 * RC$$

range: 35 ns to 70 s

for jitter free operation:

$$10 \text{ pF} \leq C \leq 10 \text{ }\mu\text{F}$$

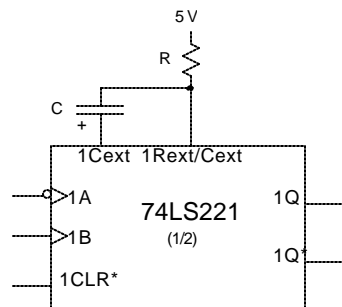

© J. Chris Perez 2001

## Counters

### Binary Counters

0000,0001,0010,...,1110,1111,0000

### BCD Counters

0000,0001,...,1000,1001,0000

### Mod-n Counters

0,1,...,n-1 or 1,2,...,n

74HC161: 4-bit Counter

74HC190 BCD up/Down Counter

© J. Chris Perez 2001

## Frequency Division Using Counters

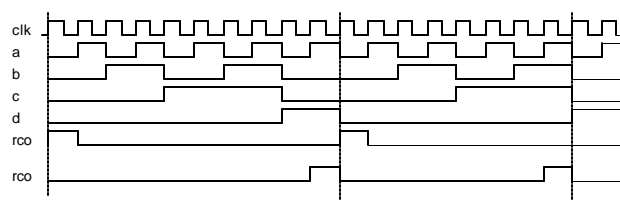

BCD Counter Timing Diagram

Each bit on the output of a counter changes at a lower frequency than the previous bit.

$$\text{Freq}_d < \text{Freq}_c < \text{Freq}_b < \text{Freq}_a < \text{Freq}_{\text{clk}}$$

How much of a difference are they?

© J. Chris Perez 2001

## Frequency Division Using Mod-n Counters

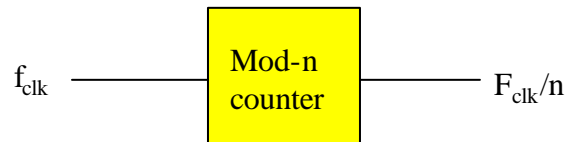

© J. Chris Perez 2001

## Experiment #3: One Shots, Clocks and Counters

**Goals:**

Learn about one-shot circuits as pulse generators.

Learn about crystal oscillators, counters and Mod-N counters.

**Prelab:**

Design a one-shot to produce an active low pulse from a positive-edge trigger.

The pulse width should be the 4 msd's of your student ID as xxx.x ms.

Suggestion Use the 74HC221 (or 74HC121) for one-shots.

Complete the schematic diagram for a crystal TTL oscillator. Use a 4MHz crystal or other available crystal (<20MHz).

Design an 8-bit synchronous counter.

Design a Mod-7 counter that counts the sequence: 1,2,3,4,5,6,7 repeat.

\*Note-Review Experiment procedure for other Prelab needs.

© J. Chris Perez 2001

**Experiment Procedure:**

- Build and test your one-shot. Measure  $V_{high}$ ,  $V_{low}$ , pulse width and rise time. Look for ringing and noise.
- Build and test your crystal oscillator. Measure:  $V_{high}$ ,  $V_{low}$ , frequency, Duty Cycle, pulse width and rise time. Measure frequency using the logic analyzer. Look for ringing and noise. Do not disassemble your circuit.
- Build and test your 8-bit counter. First use the CADET's TTL clock for trigger input. Then use a logic switch. Then use the bounceless pushbutton with a pull-up resistor.
- Connect the crystal oscillator output to the counter's trigger input. Measure the frequency at each counter output.
- Build and test your Mod-7 counter. Connect the output to a 7-segment display circuit.